

The PowerSafe® GUc product line ranges from 2256Ah to 2536Ah. The new jar design maximized power density, allowing more energy storage in a smaller space for the severe 4 to 8 hour long discharge periods used in 24VDC and 48VDC central office and mobile cellular site applications.

The unique design of the PowerSafe® GUc jar reduces footprint when placing the plates perpendicular to the rack rails for easy inspection. A 48VDC string of GUc-33 cells delivers 2536Ah and fits on an 13 foot (3.96 meter) two tier, single row rack. The GUc features a multi-directional post with a second set of holes to allow a second connection for maintenance while keeping the battery on line.

The PowerSafe GUc battery series' also uses the EnerSys Slide Lock™ post seal that allows natural positive plate growth over time without disrupting the terminal seal. In addition, the GUc battery series utilizes the EnerSys proven tongue and groove jar-to-cover seal which prevents case to cover leaks.

## BATTERY RANGE SUMMARY

### Features & Benefits

- Capacity Range: 2256Ah - 2536Ah
- Flat Plate construction-Calcium grid alloys, well suited for long duration, float applications
- Dual cross drilled post design
- Optional Flame Retardant (UL94-VO/L.O.I. 32%) container
- Slide Lock™ post seal allows natural plate growth without degrading post seal
- Innovative tongue and groove jar-to-cover seal



## General Specifications

PowerSafe® Cell Type*	Number of Cells	Nominal Voltage (V)	Capacity (Ah)	Dimensions***						Typical Weights				Typical Volume				
			@ 8hr rate to 1.75Vpc @ 77°F (25°C)	Length**		Width		Height		Unpacked		Domestic Packed		Electrolyte Only 1.215 S.G.		Short Circuit Amps		
				mm	in	mm	in	mm	in	kg	lbs	kg	lbs	kg	lbs	L	gal	
GUc-25	1	2	2256	315	12.4	384	15.1	693	27.3	191	420	200	442	45	100	37	9.9	12070A
GUc-27	1	2	2304	315	12.4	384	15.1	693	27.3	199	438	209	460	44	97	36	9.6	12890A
GUc-29	1	2	2368	315	12.4	384	15.1	693	27.3	207	456	217	478	43	94	35	9.3	13710A
GUc-31	1	2	2448	315	12.4	384	15.1	693	27.3	215	475	225	497	41	91	34	9.0	14505A
GUc-33	1	2	2536	315	12.4	384	15.1	693	27.3	224	494	234	516	40	88	33	8.7	15985A

\* Suffix number indicates total plates per cell.

\*\* 0.25" must be added between cells for spacing purposes when calculating total battery length.

\*\*\* Dimensions represent plates oriented perpendicular to the rack support rails. For optional parallel plate orientation, length and width dimensions must be switched

PowerSafe® GUc Cell Type*	Amperes			Ampere hours
	4 Hr Rate to 1.84 volts @ 77°F (25°C)	4 Hr Rate to 1.88 volts @ 77°F (25°C)	8 Hr Rate to 1.75 volts @ 77°F (25°C)	Ampere Hour Rates @ 8 Hr Rate to 1.75 volts @ 77°F (25°C)
GUc-25	415	370	282	2256
GUc-27	430	378	288	2304
GUc-29	445	389	296	2368
GUc-31	459	403	306	2448
GUc-33	474	424	317	2536

Ratings are 100% initial capacity.

## SPECIFICATIONS

- PLATE THICKNESS:**  
Positive: 0.30 in/7.6 mm  
Negative: 0.20 in/5.1 mm
- PLATE DIMENSIONS:**  
Height                      Width  
Positive: 17.6 in/447 mm    12.7 in/323 mm  
Negative: 17.6 in/447 mm    12.7 in/323 mm
- SEDIMENT SPACE:**  
1.32 in/34 mm
- ELECTROLYTE OVER PLATES:**  
2.68 in/68 mm
- CONTAINER:**  
Styrene Acrylonitrile Copolymer  
Optional Flame Retardant (UL94-V0/L.O.I. 32%) PVC
- COVER:**  
Flame Retardant PVC, UL94-V0/L.O.I. 32%
- SEPARATORS:**  
Microporous rubber
- RETAINERS:**  
"Vitrex"- glass fiber
- POST TYPE:**  
Cast Lead Posts, Cross drilled Double Posts
- POST SEAL TYPE:**  
Slide-Lock™
- PLATE SUSPENSION TYPE:**  
Positive: Bridge hung  
Negative: Bottom supported
- ELECTROLYTE WITHDRAWAL TUBE:**  
One per cell
- VENT TYPE:**  
Flame Arrestor, Fused Alumina
- FLOAT VOLTAGE SETTING:**  
Acceptable min/max: 2.17/2.26Vpc  
Recommended: 2.20Vpc
- SPECIFIC GRAVITY:**  
1.215 +0.005/-0.010 at 77°F (25°C)
- BOLT CONNECTORS:**  
Stainless steel, standard English measure, hex-head
- INTERCELL CONNECTORS:**  
Lead-plated copper, optional tin-plated copper

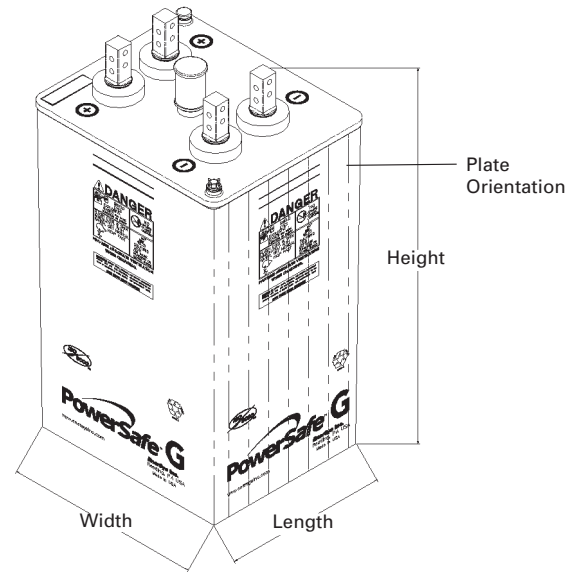

## Slide-Lock™ Post Seal

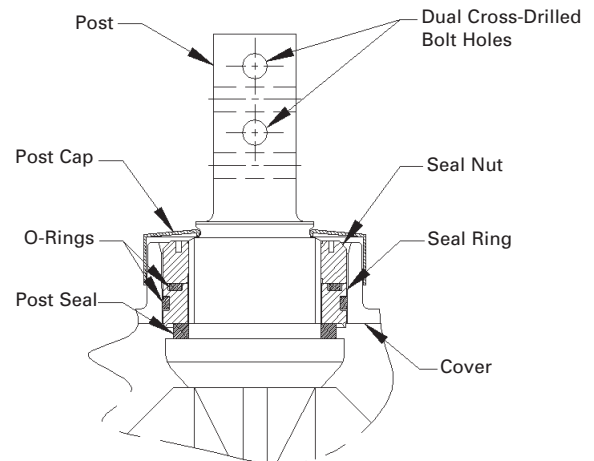

Distributed by:



www.enersys.com

**EnerSys**  
P.O. Box 14145  
Reading, PA 19612-4145  
USA  
Tel: +1-610-208-1991  
+1-800-538-3627  
Fax: +1-610-372-8613

**EnerSys Europe**  
Löwenstrasse 32  
8001 Zurich, Switzerland

**EnerSys Asia**  
152 Beach Road  
Gateway East Building  
Level 11  
189721 Singapore  
Tel: +65 6508 1780

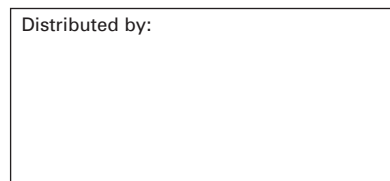

Printed in USA

© 2011 EnerSys. All rights reserved.  
Trademarks and logos are the property of EnerSys  
and its affiliates unless otherwise noted.