



# PowerSafe<sup>®</sup> GC-M

Switchgear, UPS and Utility

## Battery Performance Specifications



Visit us at [www.enersys.com](http://www.enersys.com)

**EnerSys**<sup>®</sup>

Power/Full Solutions

RESERVE  
POWER

Publication No: US-GCM-PS-AA July 2016

### Features and Benefits

- Capacity range 875 - 3550Ah
- Lead-calcium alloy
- Electrolyte reserve reduces watering requirements
- Standard Styrene Acrylonitrile (SAN) jar with flame retardant PVC UL94 V-0 cover; flame retardant PC jar and cover available
- Thick positive grids maximize performance in long discharge applications
- 20 year life expectancy in float service at 77°F(25°C) ambient temperature

### Construction

- 0.30" thick positive grids provide excellent long discharge rates and long life
- Negative plate configuration enhances high rate performance
- Separator – microporous rubber with "Vitrex" glass fiber retainers
- Electrolyte – dilute sulfuric acid with specific gravity of 1.215
- Slide-Lock™ post seal design
- Flame arrestors – included for increased operational safety

### Installation and Operation

- Space efficient footprint
- Designed to be rack mounted with easy access to posts
- Excellent long discharge and complex duty cycle capability for switchgear applications
- Lead-calcium design reduces maintenance (less watering) over traditional lead antimony batteries
- Operating temperature: 32°F (0°C) to 104°F (40°C)  
Recommended temperature: 68°F (20°C) to 86°F (30°C)

### Standards

- The management systems governing the manufacture of this product are ISO 9001:2008 and ISO 14001:2004 certified

### General Specifications

Cell Type <sup>1</sup>	Nominal Voltage*	Nominal Dimensions						Weight - Volumes							
		Length**		Width		Height		Unpacked		Domestic Packed		Electrolyte only/1.215 SG			
		in	mm	in	mm	in	mm	lbs	kg	lbs	kg	lbs	kg	gal	L
2GC-09M	875	12.4	315	15.1	384	26.4	671	375.0	170.5	395.0	179.5	136.0	61.8	13.6	51.7
2GC-11M	1020	12.4	315	15.1	384	26.4	671	410.0	186.4	430.0	195.5	127.0	57.7	12.7	48.3
2GC-13M	1140	12.4	315	15.1	384	26.4	671	445.0	202.3	465.0	211.4	119.0	54.1	11.9	45.2
2GC-15M	1225	12.4	315	15.1	384	26.4	671	485.0	220.5	505.0	229.5	111.0	50.5	11.1	42.2
2GC-17M	1540	16.6	422	15.1	384	26.4	671	585.0	265.9	607.0	275.9	163.0	74.1	16.3	61.9
2GC-19M	1630	16.6	422	15.1	384	26.4	671	620.0	281.8	642.0	291.8	155.0	70.5	15.5	58.9
2GC-21M	1695	16.6	422	15.1	384	26.4	671	655.0	297.7	677.0	307.7	147.0	66.8	14.7	55.9
2GC-23M	1745	16.6	422	15.1	384	26.4	671	695.0	315.9	717.0	325.9	139.0	63.2	13.9	52.8
GC-25M	2260	12.4	315	15.1	384	26.4	671	440.0	200.0	460.0	209.1	123.0	55.9	12.3	46.7
GC-27M	2360	12.4	315	15.1	384	26.4	671	460.0	209.1	480.0	218.2	119.0	54.1	11.9	45.2
GC-29M	2450	12.4	315	15.1	384	26.4	671	480.0	218.2	500.0	227.3	115.0	52.3	11.5	43.7
GC-31M	2515	12.4	315	15.1	384	26.4	671	495.0	225.0	515.0	234.1	111.0	50.5	11.1	42.2
GC-33M	2560	12.4	315	15.1	384	26.4	671	515.0	234.1	535.0	243.2	107.0	48.6	10.7	40.7
GC-35M	3085	16.6	422	15.1	384	26.4	671	610.0	277.3	632.0	287.3	160.0	72.7	16.0	60.8
GC-37M	3200	16.6	422	15.1	384	26.4	671	630.0	286.4	652.0	296.4	156.0	70.9	15.6	59.3
GC-39M	3300	16.6	422	15.1	384	26.4	671	650.0	295.5	672.0	305.5	152.0	69.1	15.2	57.8
GC-41M	3385	16.6	422	15.1	384	26.4	671	665.0	302.3	687.0	312.3	148.0	67.3	14.8	56.2
GC-43M	3470	16.6	422	15.1	384	26.4	671	685.0	311.4	707.0	321.4	144.0	65.5	14.4	54.7
GC-45M	3550	16.6	422	15.1	384	26.4	671	705.0	320.5	727.0	330.5	140.0	63.6	14.0	53.2

<sup>1</sup> Prefix number indicates cells per unit. Suffix number indicates total plates per cell.

\*Nominal Ah capacity is based on an 8 hour rate to 1.75 volts per cell @ 77°F (25°C)

\*\* 0.25" must be added between units for spacing purposes when calculating total battery length.

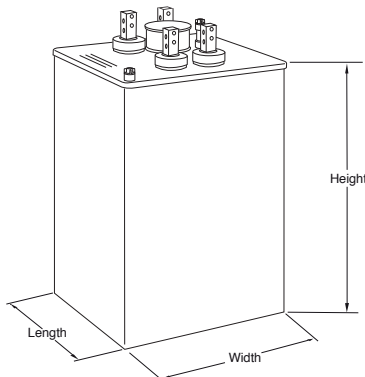

# Battery Performance Specifications

## Constant Current

Discharge Rates in Amperes\* to 1.75Vpc at 25°C (77°F)\*\*

Cell Type	NOM Ah Cap. <sup>1</sup>	Minutes			Hours									
		1	15	30	1	1.5	2	3	4	5	8	12	24	72
2GC-09M	875	717	670	549	410	331	279	216	178	153	109	79	47	20
2GC-11M	1020	877	809	666	496	398	335	258	211	180	128	92	53	22
2GC-13M	1140	1029	938	775	576	461	386	294	240	204	142	101	58	23
2GC-15M	1225	1173	1056	875	650	517	431	326	264	223	153	108	60	23
2GC-17M	1540	1404	1306	1072	788	627	524	398	324	275	192	137	78	31
2GC-19M	1630	1564	1431	1172	859	681	566	428	347	293	204	144	81	31
2GC-21M	1695	1721	1548	1266	924	729	604	454	366	308	212	149	82	31
2GC-23M	1745	1878	1658	1354	984	773	638	476	382	321	218	153	82	30
GC-25M	2260	2104	1870	1535	1137	908	760	580	473	403	282	201	116	46
GC-27M	2360	2231	1987	1633	1207	962	804	612	497	422	295	210	119	47
GC-29M	2450	2351	2099	1726	1275	1014	846	641	520	440	306	217	121	46
GC-31M	2515	2466	2205	1814	1338	1062	884	667	539	455	314	222	122	46
GC-33M	2560	2576	2306	1897	1398	1107	919	691	556	468	320	226	122	44
GC-35M	3085	2772	2487	2052	1523	1217	1020	781	640	545	386	277	160	65
GC-37M	3200	2874	2595	2146	1597	1277	1069	817	667	568	400	286	163	65
GC-39M	3300	2970	2696	2235	1667	1333	1116	851	693	589	413	294	166	65
GC-41M	3385	3065	2794	2323	1737	1389	1162	883	717	608	423	301	167	64
GC-43M	3470	3149	2890	2409	1805	1444	1207	916	742	627	434	307	169	63
GC-45M	3550	3245	2994	2503	1879	1503	1255	948	766	646	444	313	169	61

\*Ampere values listed represent 100% of the cell's initial capacity.

\*\*1.215 S.G. electrolyte at 77°F (25°C) includes intercell connector drop.

<sup>1</sup>Nominal Amp-hour capacity at the 8 hour rate.

All data subject to change without notice.

Discharge Rates in Amperes\* to 1.81Vpc at 25°C (77°F)\*\*

Cell Type	Minutes			Hours									
	1	15	30	1	1.5	2	3	4	5	8	12	24	72
2GC-09M	507	507	453	353	293	252	199	167	144	104	77	46	20
2GC-11M	632	631	552	429	354	303	237	197	170	121	88	52	22
2GC-13M	748	747	645	500	410	349	271	224	191	135	98	56	22
2GC-15M	859	857	731	565	461	390	300	246	209	146	104	58	22
2GC-17M	1025	1024	891	683	557	472	366	301	257	181	131	76	30
2GC-19M	1142	1140	976	745	605	511	394	323	274	192	138	79	31
2GC-21M	1255	1250	1054	801	648	545	417	340	288	200	143	80	30
2GC-23M	1362	1341	1128	853	688	576	438	355	300	206	147	80	29
GC-25M	1543	523	1289	994	813	691	538	443	380	269	195	113	46
GC-27M	1628	1614	1366	1052	859	729	565	465	397	280	202	116	46
GC-29M	1711	1699	1439	1106	902	763	590	484	413	290	208	118	46
GC-31M	1784	1780	1506	1156	942	795	612	500	426	297	212	118	45
GC-33M	1853	1850	1570	1203	978	824	631	514	436	301	215	118	43
GC-35M	1920	1918	1684	1299	1061	906	708	588	506	362	265	156	64
GC-37M	2021	2018	1762	1363	1114	950	741	614	527	375	273	159	64
GC-39M	2114	2111	1836	1423	1164	992	772	638	546	386	280	161	63
GC-41M	2201	2198	1909	1482	1214	1033	802	660	564	396	285	161	62
GC-43M	2282	2279	1981	1541	1264	1075	832	683	581	405	291	162	61
GC-45M	2369	2366	2058	1603	1316	1117	862	705	599	414	295	161	59

\*Ampere values listed represent 100% of the cell's initial capacity.

\*\*1.215 S.G. electrolyte at 77°F (25°C) includes intercell connector drop.

## Slide-Lock™ Post Seal

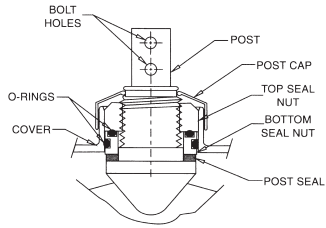

## Catalog Rint and Isc Catalog Values

Cell Type	*Resistance	Isc
	Milliohms	Amps
GC-09M	0.275	7270
GC-11M	0.240	8330
GC-13M	0.213	9380
GC-15M	0.193	10370
GC-17M	0.148	13560
GC-19M	0.138	14520
GC-21M	0.128	15630
GC-23M	0.118	16920
GC-25M	0.107	18750
GC-27M	0.101	19850
GC-29M	0.095	21050
GC-31M	0.089	22390
GC-33M	0.085	23530
GC-35M	0.076	26150
GC-37M	0.074	27070
GC-39M	0.072	27740
GC-41M	0.071	28370
GC-43M	0.069	28970
GC-45M	0.067	29930

\* Resistance values are for reference only not intended to represent an ohmic value or base line measurement.