

EAT•N

Powerware

**Powerware® 9315
Uninterruptible Power System**

Product Focus

225-750 kVA

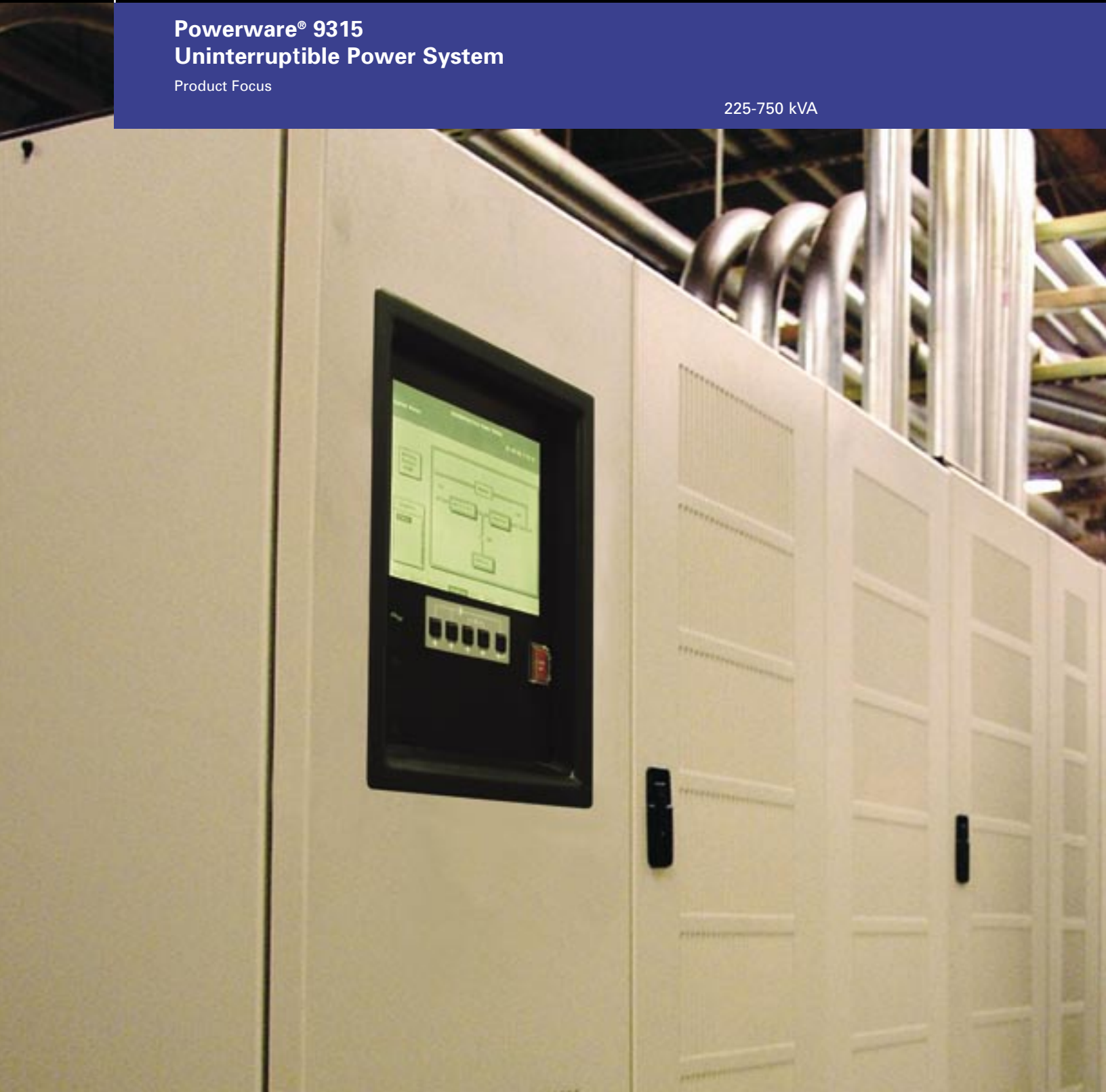

kVA Range 200-750 kVA



Powerware 9315
(200-300 kVA)



Powerware 9315
(300-500 kVA)



Powerware 9315
(625-750 kVA)

The Powerware 9315 is a highly reliable and flexible three-phase UPS. Available in single modules from 200 kVA to 750 kVA, the Powerware 9315 can be paralleled for both redundancy and capacity using patented Powerware Hot Sync™ Technology, for systems up to 3324 kW.

The pursuit of 100% availability

With technology fundamental to business survival, it's no wonder that IT managers, facility managers and CIOs feel increasing pressure to achieve zero downtime. As availability requirements rise, so does the search for the most reliable power protection system with the most advanced technology.

The 24x7 world is nothing new to us. For more than 40 years, that's exactly what our customers have demanded we address. Whether it's the NASA facility, the FAA radar sites or CitiBank's data center, Eaton has delivered maximum uptime to the most critical systems. So when we say we understand the pressure of "no downtime," you can be sure we really mean it.

Powerware 9315 UPS

The Powerware 9315 UPS series gives you maximum flexibility, reliability and system availability for your entire enterprise, whether it's in a single building or spread around the world. With highly reliable hardware, sophisticated power management software, and a multitude of accessories and options, combined with world class service, the Powerware 9315 offers the power solution – and system availability – that lets you get down to the business of your business.

Key feature elements of the 9315 include:

- Communications
- Battery management system
- Intelligent input filter
- Powerware Hot Sync™ Technology for high reliability parallel systems
- Prioritized cooling
- Field upgradeable

More than just the workhorse for data centers, facilities and network solutions, the Powerware 9315 UPS uses intelligent communications and parallel configurations for maximum uptime and availability.

The Powerware 9315 provides high efficiency operation, resulting in lower operating costs, less heat generation, cooler UPS components, and ultimately, higher reliability. High operating efficiency and superior cooling design allow the UPS to operate reliably under extreme environmental conditions.

225 kVA – 500 kVA

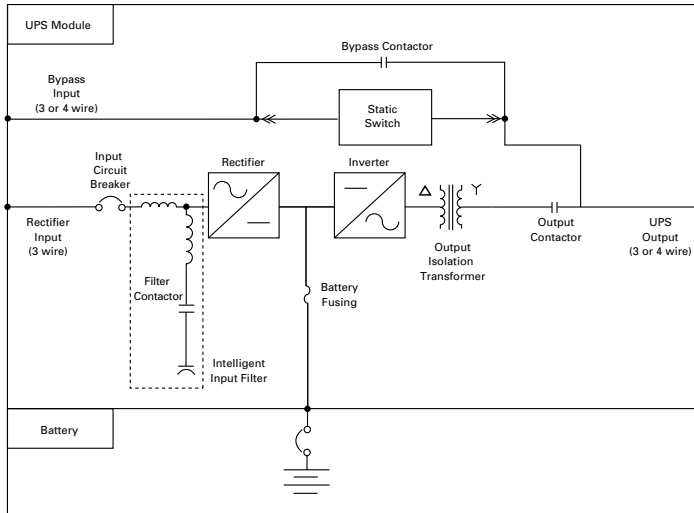

Features and Benefits

Double-Conversion Technology

Double-conversion online technology protects the critical load from all power variations on the input

DC Expert®

Monitors and maintains battery health; provides state-of-charge and dynamically updates battery time remaining information

Network Access

Optional adapters provide LAN connectivity and SNMP compatibility

Remote Notify

UPS initiates outcall for user-selected events

eNotify Remote Monitoring Option

Provides critical alerts notification and monthly reports detailing the ongoing health of the UPS and batteries. Service is enabled with the use of a Web/SNMP X-Slot card and an Eaton Powerware® UPS Service Contract

Intelligent Input Filter

Provides superior generator interface and additional isolation between input and output. Mitigates the damaging effects of harmonics, automatically turns itself off when conditions dictate, such as when the power source switches from utility to auxiliary generator power. Because it automatically configures itself, and turns itself on/off, you can be assured that your critical systems are protected, no matter what anomaly comes their way

Intelligent Design

Reduced component and wiring count significantly reduces single point-of-failure

Monitor Panel

Provides single-button controls to easily access data about UPS status

Intelligent Controls with DSP

Digital signal processing provides more pristine output signal

True PWM Technology

High speed DSP enables IGBTs to work at their highest capacity, increasing system reliability and ensuring perfect power on the output

Powerware Hot Sync

Patented paralleling technology requires no communication between modules, eliminating a system-level single point-of-failure; available for both redundant and capacity systems.

625 kVA – 750 kVA

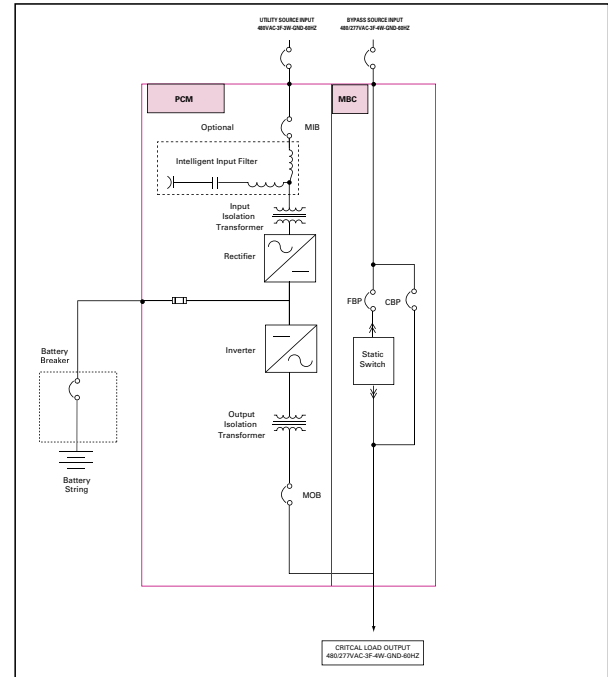

The Powerware 9315 is available in the following system configurations:

- Single Module – Reverse Transfer
- Multi-Module – Powerware Hot Sync-Redundant
- Multi-Module – Powerware Hot Sync-Capacity

Applications

- Data centers
- Server farms
- Telecommunication installations
- Internet service providers
- Transportation systems
- Security operations
- Broadcasting and entertainment
- Process control equipment
- Financial systems
- Credit card operations
- Medical / Healthcare
- Industrial systems

Communication. It's become the cultural buzzword of our time. But when you get down to brass tacks, what does it mean for you and your system availability? With the Powerware 9315, integrated communication systems and communication options give you complete control over your enterprise - and can even help prevent problems related to power long before they put your system at risk.

Communications

The Powerware 9315 features flexible, advanced communications, including:

- Local communication
 - Monitor panel
 - Illuminated indicators
 - Control panel
- Remote communications
 - Relay interface controls
 - Building alarm contacts
 - RS232 port (standard)
 - EPO kit
 - Remote monitor panel
- Optional communications
 - SNMP/Web card
 - Multi-server card (5-RS232 serial port output)
 - Single port serial card
 - Expansion chassis (Modbus® Card standard, plus two open slots)
 - X-Slot interfaces

LanSafe® UPS Monitoring Software

The LanSafe software comes free of charge with the Powerware UPSs to monitor UPS status and gracefully shutdown or restart the systems connected to that UPS during an extended power failure. In addition, it introduces a number of revolutionary features to simplify UPS monitoring and management.

PowerVision® Power Management Software



PowerVision is a Windows-based client/server software package that provides real-time monitoring of critical power conditions for the entire enterprise. It takes power management one step further by offering data archiving and analysis to prevent power problems, offering sophisticated notification and optional shutdown capabilities. Users are immediately notified of an alarm condition via a pop-up dialog box, audible alarms, or blinking, color-coded icons. Configuration flexibility allows users to tailor the system to meet their needs. PowerVision's optional Modbus gateway provides full integration with popular building management systems (BMS). Its integrated data analysis tools provide dynamic, intuitive and intelligent information that can be used to identify trends and develop cause-and-effect relationships. The suite of capabilities includes real-time and historical graphing and report generation.

FORESEER®



FORESEER Enterprise Management System is the ultimate solution to proactively monitor and manage critical facility infrastructure. Regardless of manufacturer, from UPSs, air handlers and battery monitoring to simple temperature/humidity sensors, FORESEER system monitors them all. Its interface capability and unparalleled performance analysis tools deliver the information you need to identify dangerous trends, execute corrective action, and prevent failures. Information comes across clearly and intuitively via the most advanced graphical user interface.

eNotify Remote Monitoring Service

The eNotify Service provides monthly reports detailing the ongoing health of your UPS. This report, called a Customer Monitoring Report (CMR), delivers information regarding the UPS voltage, loads, and external factors such as temperature and humidity, depending on the UPS model. This report additionally provides information about the attached batteries and system availability. All of these factors contribute to the Relative Health Index (RHI) score, which allows you to compare your UPS health relative to optimum Powerware operating levels.

Additionally, the eNotify Service informs you when critical events are experienced. This service also alerts our 24x7 Customer Reliability Center (CRC) of any critical events and provides for proactive monitoring. Anomalies are monitored via incoming parametric or event data logs, upon receipt of a status or even e-mail, respectively. If an anomaly is detected, a CRC analyst further analyzes the data for possible impending failure.

Lansafe 5



Powervision



Foreseer



Remote Monitor Panel





DC Expert® Battery Management (200-500 kVA)

DC Expert provides real-time information on battery string health and battery runtime remaining. With this integral feature, you always know the condition of your battery string. Most importantly, DC Expert allows you to plan for battery maintenance and avoid any unexpected load losses due to battery deterioration. DC Expert's battery test method outperforms the competition. Compare its battery test method to the method used by other manufacturers, and see for yourself how DC Expert's technique offers the highest level of assurance and battery runtime accuracy.

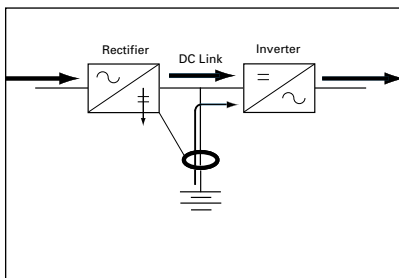

During the battery test, the rectifier regulates DC link voltage to obtain consistent battery power discharge month to month.

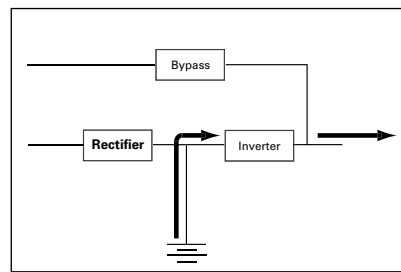

DC Expert Battery Test Method

Other UPS Manufacturers' Battery Test Methods

<ul style="list-style-type: none"> • Consistent testing proactively provides battery runtime information, accurate to +/-3% 	<ul style="list-style-type: none"> • Inconsistent battery test load yields inaccurate battery runtime estimates
<ul style="list-style-type: none"> • During a utility outage, battery time remaining automatically updates with load shedding • Battery string health determined during periodic testing • Programmable, automatic monthly testing, any day, any time • The monthly battery tests perform very light battery discharges, removing less than 10% of available battery runtime, to ensure you are always ready for a utility outage 	<ul style="list-style-type: none"> • Other UPS manufacturers use a timer that does not update as the load changes
<ul style="list-style-type: none"> • Light load testing does not impact battery life 	<ul style="list-style-type: none"> • The battery fully supports the inverter load
<ul style="list-style-type: none"> • Rectifier does not turn off during battery testing; rectifier shares load with battery for consistent battery load testing regardless of inverter load 	<ul style="list-style-type: none"> • As the critical load changes from test to test, so does the battery load • Other UPS manufacturers turn off the rectifier to initiate battery testing
<ul style="list-style-type: none"> • Since the rectifier does not turn off, the critical load is never at risk during battery testing. If a battery should fail during the test the system will recover 100%. • DC Expert log stores results of last 30 tests for trending analysis • Accommodates either valve regulated ("maintenance-free") or wet cell batteries 	<ul style="list-style-type: none"> • If the battery fails during testing, the inverter must perform an emergency transfer to bypass to prevent dropping the critical load

With the world teeming with technology that must run 24x7, 365 days a year, it's no surprise that power protection has been elevated from a dusty corner in the basement to an integral and sophisticated part of an organization's overall technology infrastructure. The Powerware 9315 offers a variety of power systems designed to integrate with your technology and meet your availability requirements.

Powerware Solutions for Redundancy and Additional Capacity

Powerware Hot Sync™ Technology

Today, your critical loads demand even greater protection. That's why we developed a unique paralleling system that provides redundancy and capacity capability with high 9's system availability.

While you may be familiar with paralleling, the patented Powerware Hot Sync's technology eliminates more risks to your system. Typically, in order for modules to operate in parallel as a system, they must communicate with each other through intricate wiring to coordinate the primary paralleling operations of output synchronization, load sharing and selective tripping of a module. But this traditional method of communication introduces a system-level single point-of-failure. If this communication link goes down, so does your critical load. And that's a risk you just can't afford to take.

Instead, Powerware Hot Sync technology eliminates the need for the modules to communicate with each other. Each UPS module has the ability to synchronize and support the critical load independent of the other modules. This unique approach to paralleling completely eliminates the traditional single point-of-failure.

Powerware Hot Sync-Redundant

This multi-module system provides unmatched system reliability and availability. This configuration allows full maintenance on any module without need for an external maintenance bypass and without having to remove the critical load from conditioned power. No other UPS manufacturer can provide this capability.

Powerware Hot Sync-Redundant with Capacity

This system topology can accommodate up to eight modules in parallel for your larger and most critical applications. Superior monitoring and highly automated controls make this system as easy to operate as a single module system.

You may not require this level of reliability now, if you are just purchasing a single UPS module. However, after the purchase you can effortlessly expand from a single module system to a two-module Powerware Hot Sync redundant system and on to an eight-module Powerware Hot Sync capacity system. Isn't it reassuring to know that the Powerware 9315 provides this degree of scalability – if you need it?

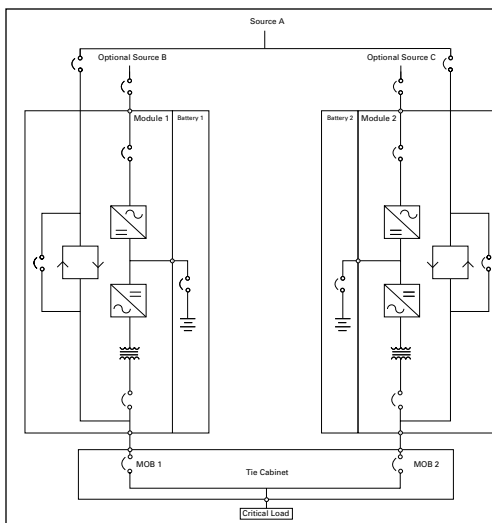

Powerware Hot Sync – Redundant
(200 - 500 kVA Modules)

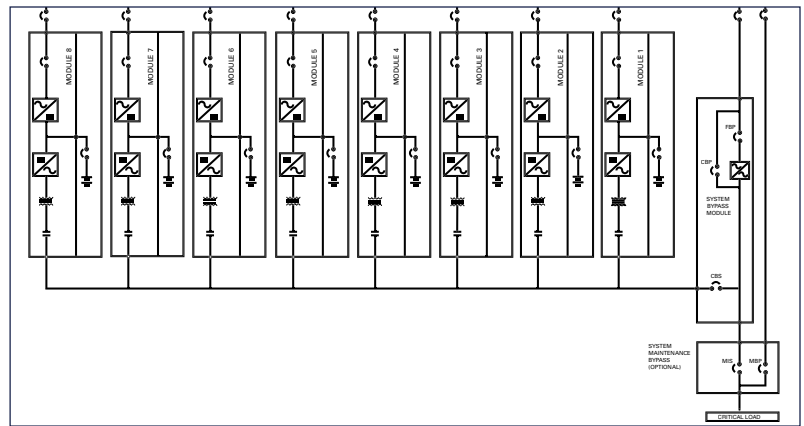

Powerware Hot Sync – Capacity /Redundant
(200 - 750 kVA Modules)



Advanced System Transfer Solutions

Powerware Hot Sync Redundant/Capacity configurations have become even more important in the development of dual path power distribution systems for critical data centers. As the quest for higher levels of availability of protected power **at the load** becomes more intense, each critical power path demands the higher reliability of the Powerware product line gained by removing cabling, connections, and components from the module topologies.

Powerware Hot-Tie™ Technology

Hot-Tie enables the user of a dual path UPS to transfer all the loads of one distribution path from one UPS to the other in order to isolate the system for growth, maintenance, or repair. The Hot-Tie circuit momentarily ties the two systems together and then opens the isolation breaker in the desired path. Work can proceed on the down system while the other UPS carries the total load. The critical distribution paths to the load are not deactivated and Static Transfer Switches are not required to change state. Hot-Tie technology coupled with Powerware Hot Sync Technology provides the user with even greater levels of redundancy and protection.

Powerware Sync Control Technology

Powerware Sync Control ensures that the output of two (or more) separate UPS systems (single module or parallel systems) remain in phase with one another so that Static Transfer Switches connected between the separate distribution paths may change state seamlessly when necessary, or so that a Powerware Hot-Tie system may be activated to transfer entire loads from one system to another.

Powerware Static Auto Tie

In order to make the semi-automatic Powerware Hot-Tie Technology fully automatic so that full system load transfers can be made autonomously, the Powerware Static Auto Tie (SAT) system was developed. The Powerware SAT system adds a wrap-around static switch to the tie breaker in the Powerware Hot-Tie system, and then adds intelligent controls so that a power protection system made up of two or more separate UPS systems can **automatically transfer entire loads** in the event of traumatic, catastrophic failure of one system...a rare but costly circumstance.

Fully Deployed - Static Auto Tie System

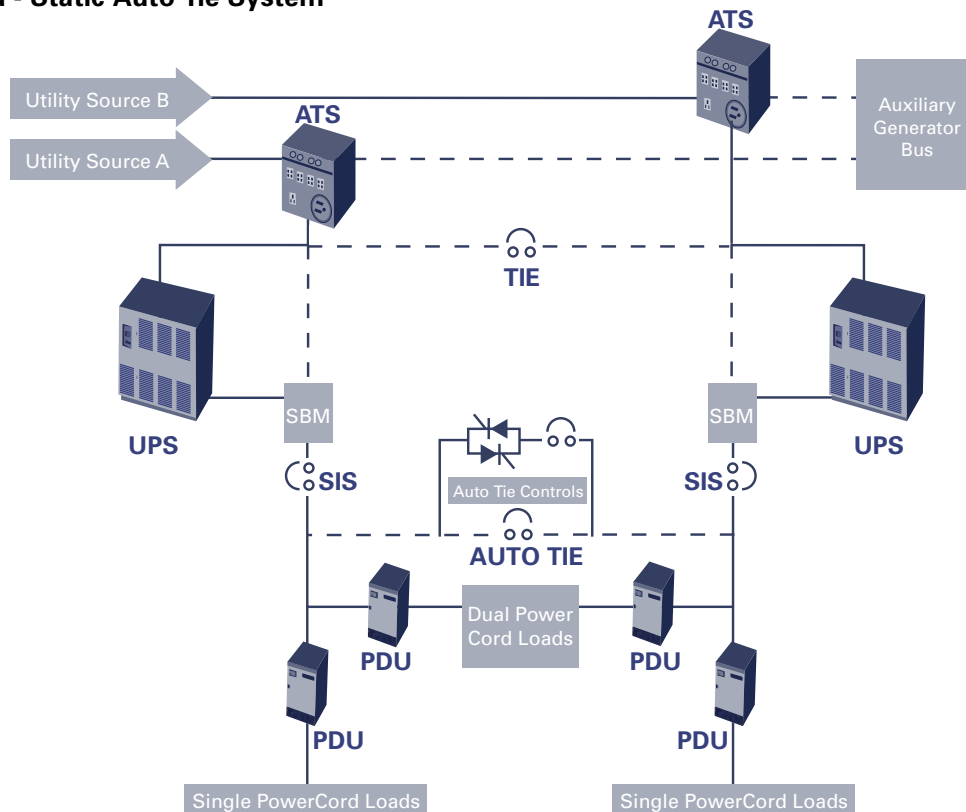

Powerware 9315 200 - 500 kVA Features

Monitor Panel

- Full size liquid crystal display provides graphical performance data, statistics, alarm history and metering
- Large easy-to-read LCD measures 191mm x 152mm (7.5" x 6")
- Push-button controls allow easy access to data through user-friendly Windows interface
- DC Expert provides state of charge and dynamically updates battery time remaining
- Operational metering features: - True RMS sensing of voltage and current - Real-time display - Displays up to 400 of the most recent events; all data is accessible via modem
- Intelligent alarm management — event record separates informational notices from situations requiring operator intervention

- Unique system performance statistics include summary information on:
 - UPS and bypass availability
 - Frequency and length of on-battery conditions
 - Building alarms
 - Time on bypass, and much more
- In addition to the LCD panel, LEDs indicate UPS operating status at a glance
- A hinged access cover protects an emergency power-off (EPO) that quickly de-energizes the UPS and critical load

Powerware 9315 500 kVA shown with doors removed



Control Panel

Easy-to-use control panel provides:

- One button start-up (with optional battery breaker)
- Bypass transfer control
- Input circuit breaker operation

Communication Panel

External communication interface accommodates remote monitoring and configuration by network or direct connection:

- Internal modem option, powered by the UPS
- System monitoring and control from any location through:
 - RS-232 and accessory ports
 - Remote terminal capabilities
 - X-Slot Cards
- Programmable building alarms



Powerware 9315
(200-300 kVA)

**Powerware 9315 (200 - 300 kVA)
shown with safety shields removed**

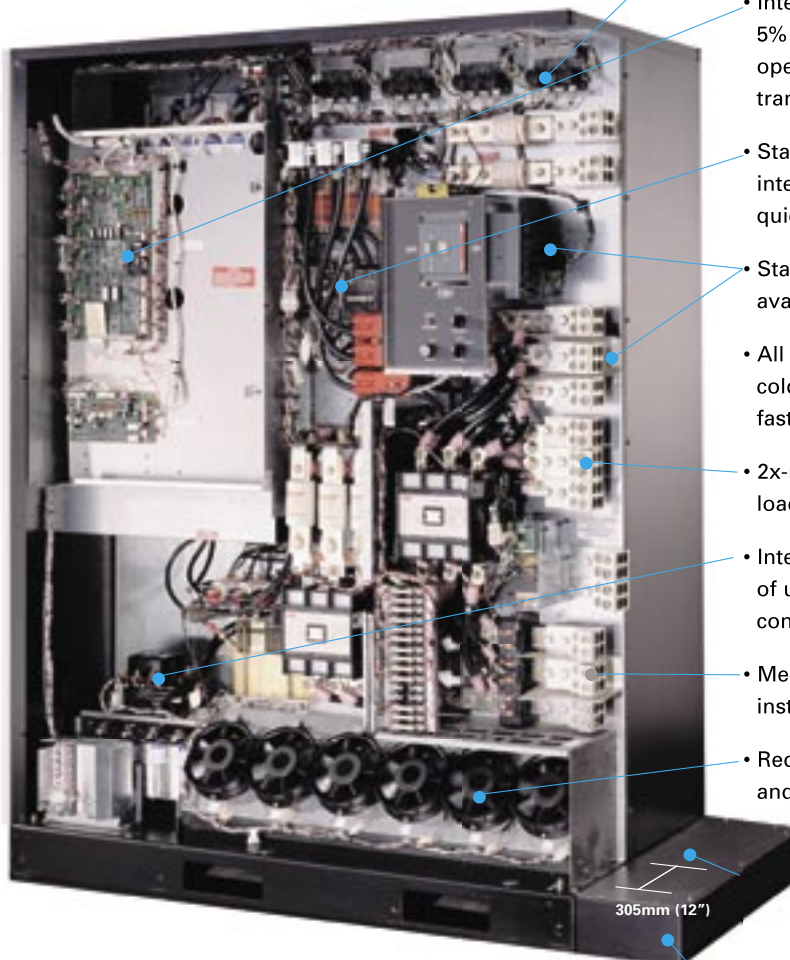

- Four power supplies support control logic for reliable online operation and provide redundant local and remote failure notification
- Intelligent controls incorporating digital signal processing provide 5% output THD, $\pm 1\%$ output voltage regulation, programmable operating limits and failure-proof make-before-break bypass transfers
- Static switch assembly can be removed for servicing without interrupting the critical load; all electrical connections feature quick disconnects for safe access
- Standard dual feed inputs for 480V and 400V increase availability (optional for other voltages)
- All power wiring is secured to magnetics with maintenance-free, cold-welded connections, eliminating periodic retorquing of fasteners and rear access requirements
- 2x-rated neutral for harmonic currents associated with non-linear loads
- Intelligent Input Filter disconnects from rectifier input with loss of utility and low load conditions, providing superior generator compatibility
- Mechanical connectors on all input and output terminals reduce installation time
- Redundant fans ensure direct consistent cooling, quiet operation and provide local and remote failure notification while supporting operational full rating up to 5000 ft. without derating
- Modular design and construction places all serviceable components within a 305mm (12") depth for easy maintenance; only requires front access for servicing convenience and low mean-time-to-repair
- Removable wireway section: 9" removable sections aid in installation
 - Powerware 9315 (200-300 kVA) reduces from 65" (1654mm) to 56" (1422mm)
 - Powerware 9315 (300-500 kVA) reduces from 74" (1880mm) to 65" (1654mm)
- Standard top or bottom entry allows for installation flexibility

Powerware 9315 750 kVA Features

Mimic Screen

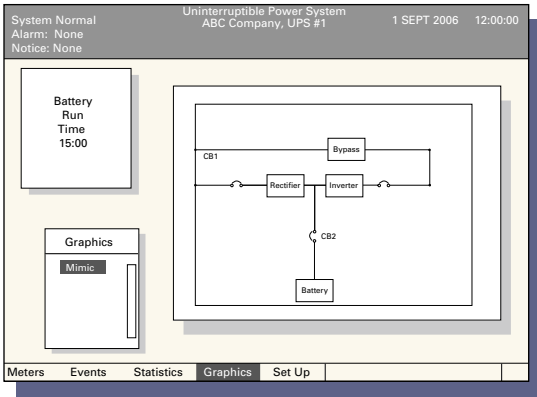

Event History Log

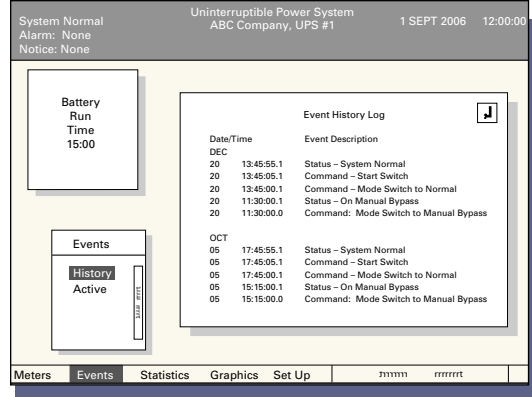

Powerware 9315 (625-750 kVA) Internal view with panels removed

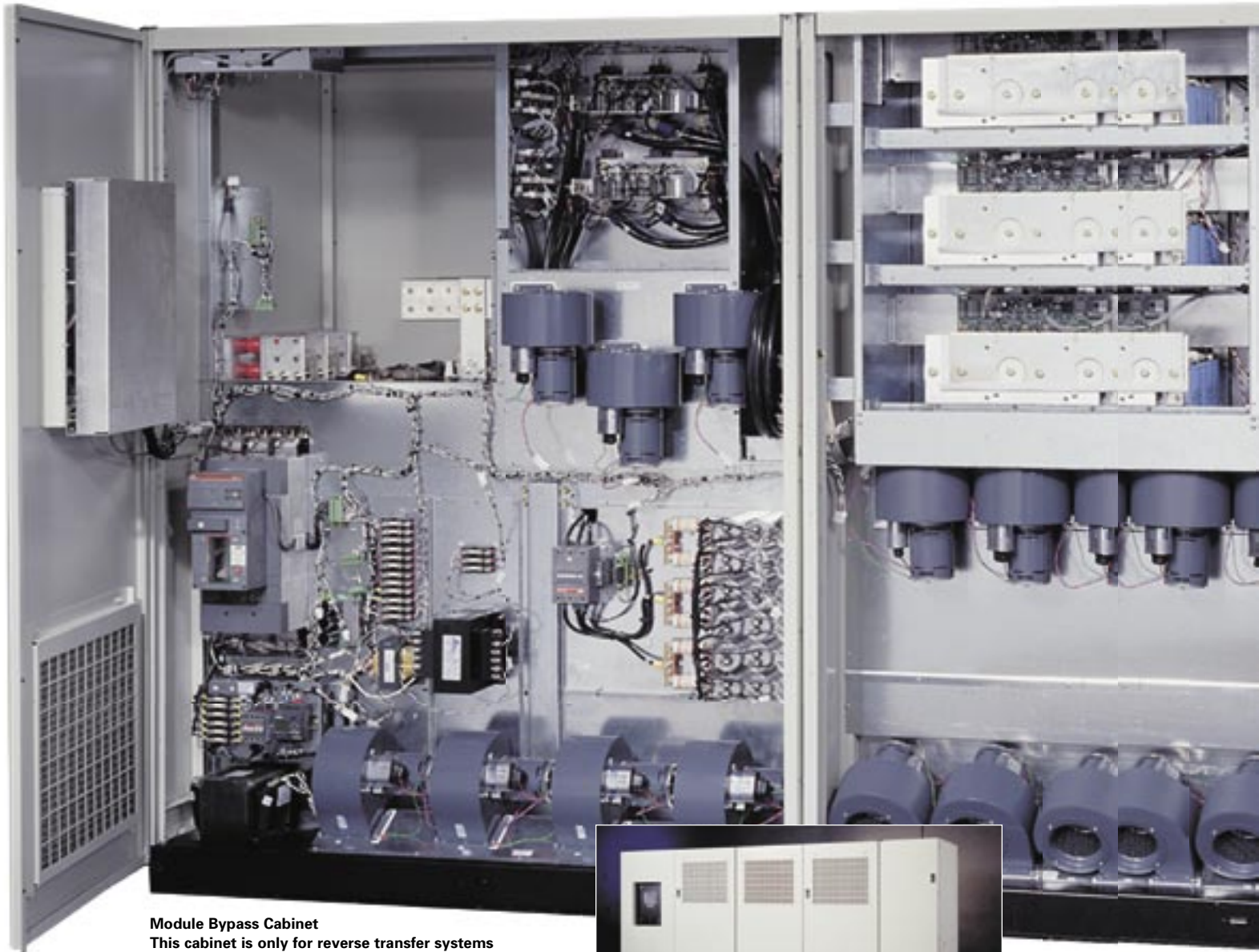

Module Bypass Cabinet
This cabinet is only for reverse transfer systems



Powerware 9315 (625-750 kVA)

Statistics Screen

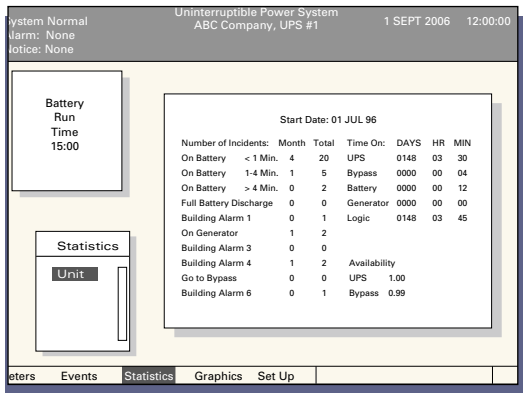

Powerware 9315-750

The Powerware 9315-750 expands the 9315 family to include a single module 750 kVA UPS. The 9315-750 includes:

- 12-pulse rectifier
- High efficiency
- High speed PWM IGBT inverter
- Input isolation transformer
- Multi-module systems

Input/Rectifier Section

- Top cable entry and dedicated wireway area (shown without cover panel)
- Motor-operated input circuit breaker automatically opens/closes as required to transfer to and from all operational modes
- Optional inrush current limiter limits the inrush current to 100% of the UPS module rated current
- Communication Panel is an easy-to-use control panel providing:
 - One button start-up (with optional battery breaker)
 - Bypass transfer control
- Optional Intelligent Input Filter disconnects from rectifier input with loss of utility and low load conditions, providing superior generator compatibility

Output/Inverter Section

- High-speed IGBT, PWM inverter section
- Redundant fans ensure direct consistent cooling, quiet operation and provide local and remote failure notification
- Motor operated output circuit breaker automatically opens/closes as required

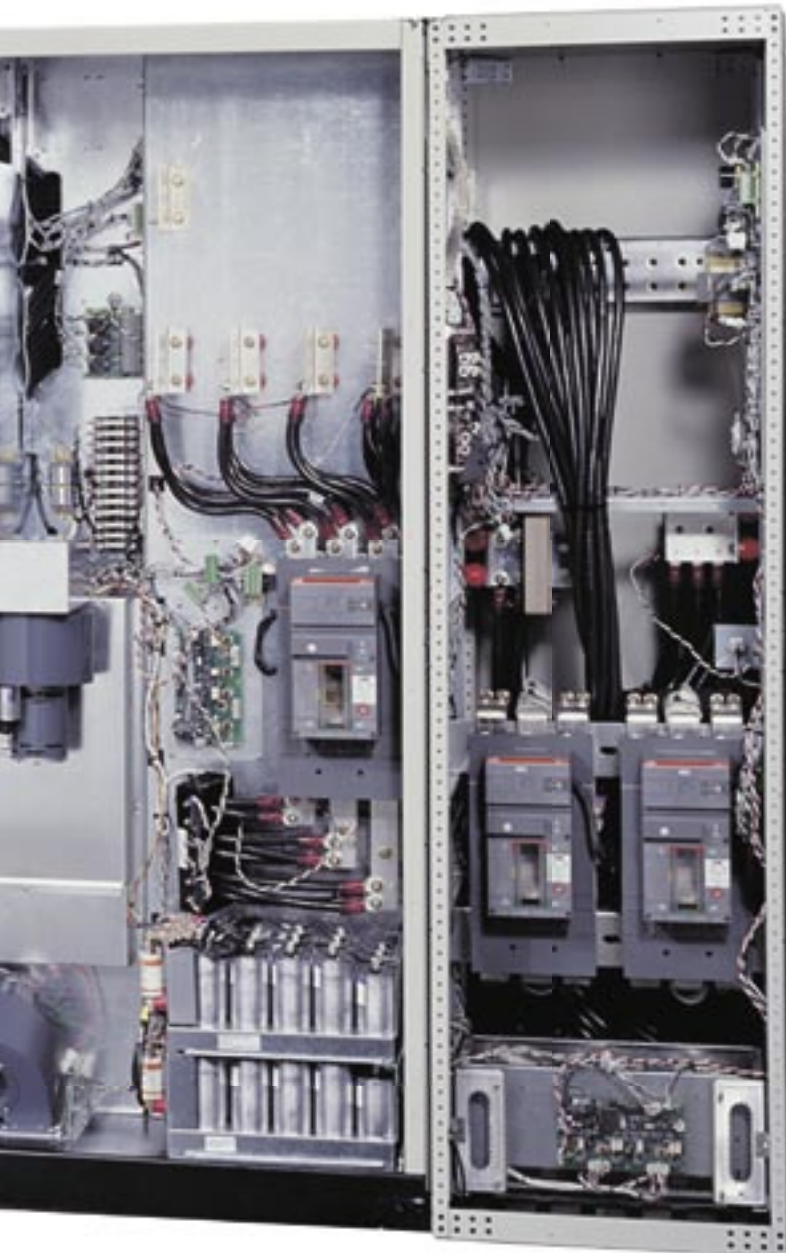

Accessories for 9315 200-750 kVA Systems

Maintenance Bypass Module

This floor-mounted, enclosed cabinet provides continuous support for critical loads during servicing or testing of the UPS module. The MBM includes the maintenance isolation breaker (MIS) and maintenance bypass breaker (MBP).

Powerware Power Distribution Units and Remote Power Panels

The Powerware PDU provides reliable data center power distribution for both raised and non-raised floor applications. To ensure the high performance required for today's data centers, this Eaton designed and manufactured PDU provides the following in an integrated, factory- tested package:

- Isolation
- Voltage transformation
- Electrical distribution
- Equipment protection
- Computer-grade grounding

Remote Monitor Panel (RMP)

The RMP allows customers to monitor the operational status of the UPS system from virtually any location within a facility. The RMP utilizes simple backlit status indicators and an alarm horn that notify customers of changes in the operational status of the UPS system. This option can be installed in multiple locations throughout a facility.

Relay Interface Module (RIM)

The RIM provides a critical communications link to optimize reliability, utilizing serial interface and relay contact closures to support up to eight critical loads. The RIM notifies customers of operational status changes, allowing them to respond with the appropriate action.

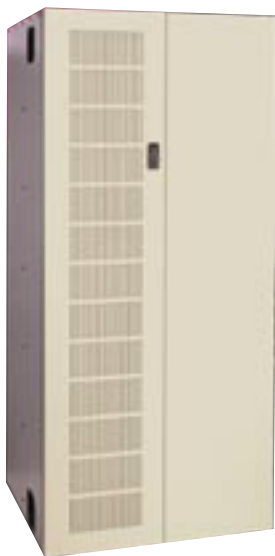

Maintenance Bypass Module



Eaton PDU

Powerware Services

The Powerware 9315 is supported by Eaton's comprehensive services plans to provide you with system uptime, convenience, and value. We support the UPS, batteries, and related equipment with remote monitoring and onsite services to meet your specific site or application needs. Our Customer Reliability Center is open seven days a week, twenty-four hours a day to monitor your systems and respond to your needs. Our factory-trained service technicians are deployed across the world to deliver speedy, reliable services.

Additional service offerings include:

- Installation and project management
- Complete line of power systems maintenance plans (covering parts and labor) to match any need—from basic UPS and/or battery support to all-inclusive packages that delivers ongoing piece-of-mind.
- Remote monitoring services to support maximum uptime
- First responder training classes for your employees
- kVA upgrades and power systems enhancements for existing equipment
- Spare parts kits

Custom Solutions

For any set of customer specifications, there are many possible approaches that will work. Eaton can identify the best approach from among several feasible alternatives that delivers dramatic cost savings and performance enhancements for you. Eaton works with your engineering firms to design, source, integrate, test, and project manage large systems that include generators, switchgear, and other electrical products from Eaton or other manufacturers.

Our dedicated application engineers translate specifications into a proposal. Project engineers make sure that proposal is manufactured, sourced, integrated, and tested to meet those specifications. Sales engineers provide a dedicated point of contact.

Eaton can deliver a customized solution that matches your needs more closely than anyone else.

PowerChain Management Solutions

Eaton's PowerChain Management™ solutions offer a breakthrough approach to managing the power system. It is a holistic and system-wide perspective of the entire power chain that also takes into account the management of the entire life cycle. Our comprehensive, end-to-end products and services uniquely position us to address our customers' critical needs. To this end, the 9315 works with a variety of Eaton products to complete your power chain needs.



PRODUCT (kVA MODELS)

	9315-200 (200 kVA)	9315-225 (225 kVA)	9315-250 (200-250 kVA)	9315-300 (225-300 kVA)	9315-400 (400-500 kVA)	9315-500 (400-500 kVA)	9315-625 (500-625 kVA)	9315-750 (625-750 kVA)
Standard Features								
Casters and Leveling Feet	–	–	–	–	–	–	–	–
DC Expert™ System	•	•	•	•	•	•	–	–
Ethernet Compatibility	•	•	•	•	•	•	•	•
Field kVA Upgrade Capability	–	–	•	•	•	•	•	•
Input Filter (THD 7%) in U.S.	–	–	–	–	–	–	–	–
LCD monitor Panel	•	•	•	•	•	•	•	•
Output Isolation	•	•	•	•	•	•	•	•
Bypass Isolation	–	–	–	–	–	–	–	–
SNMP Capability	•	•	•	•	•	•	•	•
Token Ring Compatibility	•	•	•	•	•	•	•	•
Top & Bottom Wire Entry	•	•	•	•	•	•	–	–
ProActive Service Plan	•	•	•	•	•	•	•	•
Optional Features								
ConnectUPS Adapters	•	•	•	•	•	•	•	•
Hot Sync Redundant	•	•	•	•	•	•	–	–
Hot Sync Capacity	•	•	•	•	•	•	•	•
Input Filter (THD 7%) U.S.	•	•	•	•	•	•	•	•
Input Filter (THD 7%) non U.S.	•	•	•	•	•	•	•	•
Input Isolation Transformer	•	•	•	•	•	•	2	2
Internal Modem	•	•	•	•	•	•	•	•
Maintenance Bypass Panels	•	•	•	•	•	•	•	•
Output Power Distribution Panels	•	•	•	•	•	•	•	•
Power Management Software	•	•	•	•	•	•	•	•
Relay Interface Module	•	•	•	•	•	•	•	•
Remote Monitor Panel	•	•	•	•	•	•	•	•
Remote Notify	•	•	•	•	•	•	•	•
Server Shutdown via OnliNet/LanSafe	•	•	•	•	•	•	•	•
SNMP Adapters	•	•	•	•	•	•	•	•

1 For 300/400/415 V, 50/60 Hz. 2 Standard feature

Environmental Specifications

Ambient Temperature:	0°C to +40°C
Storage:	–20°C to +70°C
Relative Humidity:	0-95% non-condensing
Altitude:	1500 meters (5000ft.) at 40°C ambient temperature without load derating
Audible Noise:	At 1 meter; in accordance with ISO 7779: Powerware 9315 (225-300 kVA): less than 69dBA Powerware 9315 (300-500 kVA): less than 72dBA Powerware 9315 (500-750 kVA): less than 75dBA
Electrostatic Discharge:	withstands 6 kV (up to 500 kVA withstands 8 kV) without damage or disturbance to the load; exceeds requirements of IEC 801-2 EMC: Meets FCC Class A 5 and EN 50091-2 (CISPR 22, Class A)

Input Specifications

Voltage Range:	(refer to product data sheets)
Frequency Range:	(60 Hz) 57-63 Hz; (50 Hz) 47-53 Hz
Surge Protection:	Meets IEEE 587, Category A & B, EN 50091-2 and EN 50082-2
Power Factor:	0.95 typical at full load with optional input filter Input current distortion less than 7% typical with optional input filter

Output Specifications

Output voltage THD:	(linear load): less than 3% for a 100%; (linear load); 2% for a single harmonic; Output voltage THD (non-linear): less than 5% when tested in accordance with EN50091-3.
Voltage Regulation:	Better than ±1%
Transient Response:	Less than 5% for 100% load step; full recovery within 1 cycle
Frequency:	(Free Run) ±0.005 Hz
Frequency Sync Range:	±0.5 Hz
Frequency Slew Rate:	1 Hz/second maximum
Voltage Adjustment Range (Operator):	±5%

Battery Specifications

Matching Battery Type:	Sealed, valve regulated lead acid
Recharge Time:	10–12 times the discharge time to 95%
Other Battery Options:	Wet cell and nickel-cadmium batteries; open racks available

Safety

UL1778 Listed
UL CAN/CSA C22.2 NO.107.1 Listed, EN 50091-1
All Cabinets provide seismic mounting features
Selectable DC ground fault detection capability

UNITED STATES
8609 Six Forks Road
Raleigh, NC 27615 U.S.A.
Toll Free: 1.800.356.5794
or 919.872.3020

www.powerware.com

CANADA
Ontario: 416.798.0112

LATIN AMERICA
Argentina: 54.11.4343.6323
Brazil: 55.11.3616.8500
México: 52.55.5488.5252

EUROPE/MIDDLE EAST/AFRICA
Denmark: 45.3686.7910
Finland: 358.94.52.661
France: 33.1.6012.7400
Germany: 49.7841.666.0
Italy: 39.02.66.04.05.40
Norway: 47.23.03.65.50
Sweden: 46.8.598.940.00
United Kingdom: 44.1753.608.700

ASIA PACIFIC
Australia/NZ: 61.2.9693.9366
China: 86.21.6361.5599
HK/Korea/Taiwan: 852.2745.6682
India: 91.11.2649.9414 to 18
Singapore/SEA: 65.6829.8888

Powerware, Powerware Hot Sync, DC Expert, PowerVision, and Foreseer are trademarks and/or service marks of Eaton Electrical, Inc.



Powerware

© 2006 Eaton Corporation
All Rights Reserved
Printed in USA
PLS02FYA
May 2006