

# ECS Retrofit Power Solution

Cost-Effective Energy Efficiency Upgrade



- Preserves distribution and cabling investments
- Modern Galaxy Pulsar Plus controller
  - Adaptive Rectifier Management (efficiency management)
  - Thermal compensation and battery management features
- -48V up to 600A (16.2 KW) or +24V up to 1200A (16.3 KW)
- Efficiency approaching 97%

## Overview

GE Energy offered the Lineage 2000 ECS telecom power systems throughout the 1980s and 1990s. The ECS Retrofit Power Solution enables these legacy power systems to be upgraded to modern rectifiers and controller technology, while leaving the distribution, shelves and frame in place.

The ECS Retrofit Power Solution upgrades the legacy 364 series rectifiers with GE Energy Infinity™ series of rectifiers to improve energy efficiency and deliver centralized management visibility and control. The Infinity rectifiers are managed by the modern Galaxy Pulsar Plus™ controller.

All existing system rectifier shelf slots require a retrofit carrier or permanent slot filler since all rectifiers deployed in an ECS system must be upgraded. The desired capacity of standard Infinity rectifiers are then inserted into the retrofit carrier modules. No change is needed to the output distribution, batteries, or LVD contactor of the ECS plants with this retrofit.

The ECS retrofit power solution provides a turn-key, cost-effective maintenance upgrade for the installed base of ECS telecom power systems. For most applications, the retrofit procedure may be accomplished in less than 4 hours.

## Benefits

### Reliability

- Extends the lifecycle of deployed ECS power plants
- Proven field performance
- Controller continuity

### Intelligence

- Industry leading controller features
- Ethernet interface for remote access
- Centralized network management

### Investment Protection

- Energy efficiency improvement
- Avoids complete replacement costs

### On Time Delivery

- Comprehensive turn-key retrofit service including plant assessment
- Fast track deployment
- 24/7 support

### Total Efficiency

The GE Energy Total Efficiency™ (TE) architecture reduces energy loss and lowers cooling costs by 50-70%. TE products will prioritize sustainable energy sources like solar, wind, water and fuel cells over traditional utility grid or diesel generator sources – and they will intelligently respond to smart grid information to reduce consumption during peak demand periods. Active Rectifier Management™ (ARM) and Battery Charging Optimization™ (BCO) features increase efficiency on current and legacy power infrastructures. The Total Efficiency architecture addresses issues end-to-end based on our proven experience and expertise in batteries, power distribution, DC energy systems, AC-DC power supplies, and DC-DC board mounted power to deliver a solution that is more safe, reliable and energy efficient than alternatives from our competitors.



## Infinity TEZ Rectifiers



- **Compact** - 1RU form factor providing high power density (24 W/in3)
- **Plug and Play** – installation of the rectifier in a shelf connected to a compatible system controller initializes all set up parameters automatically. No adjustments are needed.
- **Extended service life** – parallel operation with automatic load sharing ensures that parallel units are not unduly stressed even when a unit fails or is removed.
- **Monitoring / control** – the built in microprocessor controls and monitors all critical rectifier functions and communicates with the system controller using the built in Galaxy Protocol serial interface.
- **Fail safe performance** – hot insertion capabilities allow for rectifier replacement without system shutdown; soft start and inrush current protection prevent nuisance tripping of upstream breakers.

### Applications

- Telecommunications networks
- Digital subscriber line (DSL)
- Indoor/outdoor wireless
- Routers/switches
- Fiber in the loop
- Transmission
- Data networks
- PBX

### Key Features

- Extended temperature range
- Redundant fan cooling
- Front panel LED indicators
- 1U height, hi power density
- +24 or -48V input
- Digital load sharing
- Hot pluggable
- RoHS compliant

### Specifications

Input	NE100AC24ATEZ	NE050AC48ATEZ
Voltage Range	95-275Vac	95-275Vac
Input Current	15-12A @100-120Vac 15A @200-240Vac	15-12A @100-120Vac 15A @200-240Vac
Input Frequency	45 – 66Hz	45 – 66Hz
Power Factor	0.98 at>50% load	0.98 at>50% load
Efficiency	> 95% (Peak 95.6%)	> 96% (Peak 96.9%)
Total Harmonic Distortion	< 5% @loads over 50%	< 5% @loads over 50%
Output		
Voltage Adjust Range	21-29Vdc	42-58Vdc
Voltage Nominal	27.25V	54.5V
Regulation(with controller)	±0.5%	±0.5%
Ripple	100mVrms	100mVrms
Output Current - High-Line - Low-Line	100A @27.25V 44A @27.25V	50A @54.5V 22A @54.5V
Heat Dissipation @ max out	174W / 594 BTU/hr	158W / 539 BTU/hr

Environmental	
Operating Temperature	-40°C to +75°C (-40 to 167°F)
Storage Temperature	-40°C to +85°C (-40 to 185°F)
Humidity	< 95% non-condensing
Altitude	2000M max
Mechanical	
Length (inch/mm)	13.85 / 352
Width (inch/mm)	5.23 / 133
Height (inch/mm)	1.63 / 42
Weight (lb/Kg)	5.05 / 2.2
Safety and Standards Compliance	
NEBs	Evaluated by independent NRTL test lab to Telcordia GR63, Issue 3 & GR 1089, Issue 5
Safety	UL 60950-1, 2nd Ed. Recognized CSA C22.2 No. 60950-1-03 Certified
RoHS	Compliant to RoHS EU Directive 2002/95/EC; RoHS 6/6
EMC	European Directive 2004/108/EC; EN55022, Class A; EN55024; FCC, Class A; GR1089-CORE, Issue 5

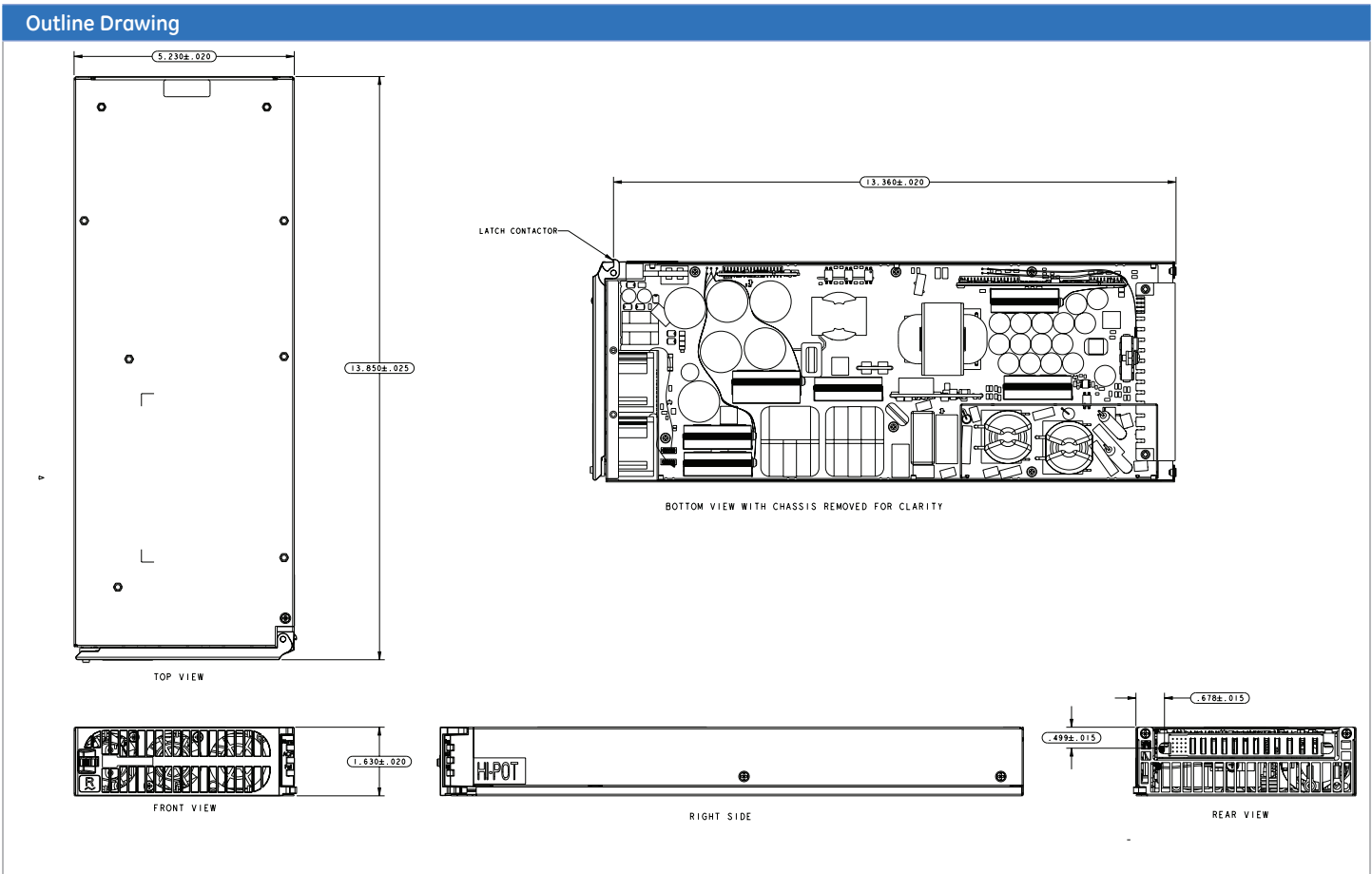

## Pulsar Plus Controller



The Pulsar Plus family of controllers provides system monitoring and control features for Infinity, CP, and other power systems. These controllers monitor and control system components including rectifiers, converters, and distribution modules via a multi-drop RS485 digital communications bus. System status, parameters, settings, and alarm thresholds can be viewed and configured from the controller's front panel display. Assignment and configuration of alarm inputs and output relays can be performed from a laptop computer connected to a local RS-232 or Ethernet port, or by remote access is through a network connection to the

World Wide Web (internet) or your enterprise network (intranet). An optional modem is also available.

This controller utilizes standard network management protocols allowing for advanced network supervision. GE Energy Galaxy Manager™ software is the centralized visibility and control component of a comprehensive power management system designed to meet engineering, operations and maintenance needs. The Galaxy Manager client-server architecture enables remote access to system controllers across the power network.

### Applications

- Telecommunications networks
- Digital subscriber line (DSL)
- Indoor/outdoor wireless
- Routers/switches
- Fiber in the loop
- Transmission
- Data networks
- PBX

### Key Features

#### Remote Access and Features

- Integrated 10/100Base-T Ethernet Network
  - TCP/IP
  - SNMP V2c for management
  - SMTP for email
  - Telnet for command line interface
  - DHCP for plug-n-play
  - FTP for rapid backup and upgrades
  - HTTP for standard web pages and browsers
  - Compatible with Galaxy Manager and other management packages
  - Shielded RJ-45 interface referenced to chassis ground
- Password protected security levels: User, Super-User, Administrator for all access
- Ground-referenced RS232 system port
- ANSI T1.317 command-line interface
- Modem access support
  - Remote via external modem
  - Callback security
- EasyView2, Windows-based GUI software for local terminal or Modem access

#### Standard System Features

- Monitor and control of more than 60 connected devices
  - Robust RS485 system bus
- Standard and user defined alarms
  - Alarm test
  - Assignable alarm severity: Critical, Major, Minor, Warning, and record-only
  - 10 alarm relays (7 user assigned)
- Rectifier management features
  - Automatic rectifier restart
  - Active Rectifier Management ARM (energy efficiency)
  - Remote rectifier (on/off)
  - Reserve Operation
  - Automatic rectifier sequence control
  - N + X redundancy check
- Multiple Low Voltage Load and Low Voltage Battery Disconnect thresholds
- Configuration, statistics, and history
  - All stored in non-volatile memory
  - Remote/local backup and restore of configuration data
- Industry standard defaults
  - Customer specific configurations available
- Remote/ local software upgrade
- Basic, busy hour, and trend statistics
- Detailed event history
- User defined events and derived channels

#### Standard Battery Management Features

- Float/boost mode control
  - Manual boost
  - Manual timed boost locally, T1.317, and remotely initiated
  - Auto boost terminated by time or current
- Battery discharge testing
  - Manual (local/remote)
  - Periodic
  - Plant Battery Test (PBT) input driven
  - Configurable threshold or 20% algorithm
  - Graphical discharge data
  - Rectifiers on-line during test
- Slope thermal compensation
  - High temperature
  - Low temperature
  - Step temperature
  - STC Enable/Disable, low temperature Enable/Disable
  - Configurable mV/°C slopes
- State of charge indication
- High temperature disconnect setting
- Reserve-time prediction
- Recharge current limit
- Emergency Power-Off input

**Integrated Monitoring Inputs/Outputs**

- System plant voltage (accuracy  $\pm 0.04V$ , resolution 0.01V)
- One system shunt (accuracy  $\pm 0.5\%$  full scale, resolution 1A)
  - Battery or load
  - Mounted in the return side of DC bus
- Up to 15 binary inputs
  - Six inputs close/open to battery
  - 9 input close/open to return
  - User assignable
- Up to 7 Form-C output alarms (60VDC @ .5A)
  - User assignable
- 1-Wire™ bus devices
  - Up to 16 temperature probes (QS873)
  - Up to 6 mid-string monitors (ES771)

General	
Operating Voltage	$\pm 24$ Vdc, $\pm 48$ Vdc (Range: $\pm 18$ to $\pm 60$ Vdc)
Input Power	Less than 7W
Operating Temperature Range	-40°C to +75°C (-40 to 167 °F)
Operating Relative Humidity	0 - 95% (non-condensing)
Storage Temperature Range	-40°C to +85°C (-40 to 185 °F)
Physical Specifications	Sizes vary by packaging option
Display	8-line by 40-character with alarm context sensitive backlit LCD

**Galaxy Manager Compatible**

- Centralized web server and database with multiple user access to live or managed data with drill down to problem details
- Monitor and control of more than 40 connected devices
- Management information from polling or alarms received from alarm traps from multiple sites are available on one screen via the inter/intranet
- Trend user selected data over time
- Automatic or manual report generation
- Standard engineering tools like reserve time calculators and cable voltage drop analyzer

Safety and Standards Compliance	
NEBs	Evaluated by independent NRTL test lab to Telcordia GR63, Issue 3 and GR1089-CORE, Issue 5
Safety	CSA C22.2 No. 60950-1-03 Certified for Canada and U.S.; UL60950-1 1st Ed.
RoHS	Compliant to RoHS EU Directive 2002/95/EC RoHS 5/6
EMC	European Directive 2004/108/EC; EN55022, Class A; EN55024; FCC, Class A; GR1089-CORE, Issue 5

Agency Certifications	
NEB Level 3	Evaluated by independent NRTL test lab to Telcordia GR63, Issue 3 and GR1089-CORE, Issue 5
EMC	European Directive 2004/108/EC; EN55022 (CISPR22) Class A; EN55024 (CISPR24)
Safety	Underwriters Laboratories (UL) Listed per Subject Letter 1801: Power Distribution Center for Communications Equipment, and cUL Certified (CSA 22.2 950): Safety of Information Technology Equipment

## Step 1: Select Retrofit Power Solution Kit

All selections in Step 1 include all the necessary components to convert the rectifier shelf assembly from an ECS shelf to an upgraded NE rectifier shelf. Choose 1, 2, or 3 shelf solutions for either 48 volt or 24 volt power systems. Regardless of the chosen solution, no remaining 364 (364A2, 364A3, 364B1, 364B2) rectifiers may remain in the power system.

With this conversion process the original equipment 364 rectifier will no longer function properly. Where future growth is required, the user must install additional rectifier carriers equipped with the appropriate NE Rectifier.

RPS Kit Number	Model	RPS Kit Description
ECS24V1SEQ	24V ECS Retrofit Power Solution Kit (1 Shelf)	Each ECS RPS Kit Includes: - Pulsar controller upgrade - Rectifier slot carrier for each shelf position - QS873A Thermal Probe (A) -10 ft wire set (B: thermal probe to controller)  NOTE: Work methods involved in this conversion also include controller replacement, circuit board change outs, and system reboot. Expertise beyond a user level technician may be required to complete the conversion process.
ECS24V2SEQ	24V ECS Retrofit Power Solution Kit (2 Shelf)	
ECS24V3SEQ	24V ECS Retrofit Power Solution Kit (3 Shelf)	
ECS24V4SEQ	24V ECS Retrofit Power Solution Kit (4 Shelf)	
ECS48V1SEQ	48V ECS Retrofit Power Solution Kit (1 Shelf)	
ECS48V2SEQ	48V ECS Retrofit Power Solution Kit (2 Shelf)	
ECS48V3SEQ	48V ECS Retrofit Power Solution Kit (3 Shelf)	
ECS48V4SEQ	24V ECS Retrofit Power Solution Kit (4 Shelf)	



NOTE: Determine if your ECS plant is utilizing the data monitoring feature. If so, please contact your GE Energy representative for additional required monitoring.





## Step 2: Select Rectifier Carriers

The kit solutions in Step 1 are intended to simplify the order process. However, the following components may be ordered individually when necessary.

Ordering Code	Description	Photo
CC109159397	<b>24V Rectifier Carrier, Includes:</b> Carrier adapts the NE rectifier to be placed in the ECS shelf No rectifier is included in this kit	
CC109159026	<b>48V Rectifier Carrier, Includes:</b> Carrier adapts the NE rectifier to be placed in the ECS shelf No rectifier is included in this kit	
850014640	<b>ECS Blank</b> Use permanent style filler blanks for shelf slots not equipped with rectifier carriers	

### Step 3: Select Rectifiers

Each NE Rectifier carrier may be equipped with one new NE Rectifier per available slot. Each 24 volt rectifier slot may be equipped with one 100 Amp rectifier, each 48 volt rectifier will accept one 50 Amp rectifier.

Output	Ordering Code	Description	Photo
	CC109160834	95 - 145Vac input, 24V, 44A Output, 175 - 275Vac input, 24V, 100A output; 145 - 175 linear output increase from 44A to 100A	
100A		NE100AC24ATEZ	
	CC109158878	95 - 145Vac input, 48V, 22A Output, 175 - 275Vac input, 48V, 50A output; 145 - 175 linear output increase from 22A to 50A	
50A		NE050AC48ATEZ	



### Step 4: Controller Kit

The kit solutions in Step 1 are intended to simplify the order process. However, the following components may be ordered individually when necessary.

Ordering Code	Description	Photo
CC109159018	ECS Retrofit Controller Kit, includes everything needed to update existing controller to the Galaxy Pulsar Plus	

## Step 5: LVD Strap

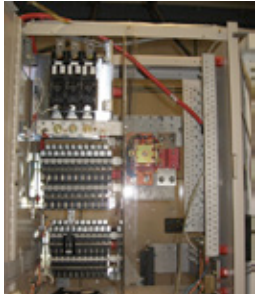
The kit solutions in Step 1 are intended to simplify the order process. However, the following components may be ordered individually when necessary.

Ordering Code	Description	Photo
CC848907881	ECS Retrofit contactor strapping kit, J85500D3 with L23 – L27 or H569-420 (if load < 300A) Plants	
CC848909515	ECS Retrofit contactor bus bar strapping kit, J85500E or H569-416 Plants	
CC109164141	ECS Retrofit contactor strapping kit, J85500G Plants	



## Step 6: Order Additional Battery Monitoring

The kit solutions in Step 1 are intended to simplify the order process. However, the following components may be ordered individually when necessary.

Ordering Code	Description	Photo
CC109142980	QS873A Thermal Probe (A)	
CC848817024	10 ft wire set (B: thermal probe to controller)	
CC109157434	20 ft wire set (B: thermal probe to controller)	
CC848822560	1 ft wire set (C: thermal probe to thermal probe)	
848719803	5 ft wire set (C: thermal probe to thermal probe)	
CC848822321	10 ft wire set (C: thermal probe to thermal probe)	
108958422	ES771A Battery Voltage Monitor Card	
CC848791517	2-1/2 ft wire set (D: ES771A to thermal probe)	
CC848797290	6 ft wire set (D: ES771A to thermal probe)	
848719829	10 ft wire set (D: ES771A to thermal probe)	
CC848791500	4 ft wire set (G: ES771A to ES771A or controller)	
848652947	10 ft wire set (G: ES771A to ES771A or controller)	
555052-1	In-Line Coupler (for extending item G above)	

Temperature/Voltage probes are needed for battery monitoring. They are connected to each battery or battery string to provide slope thermal compensation, temperature alarms and voltage imbalance alarms.

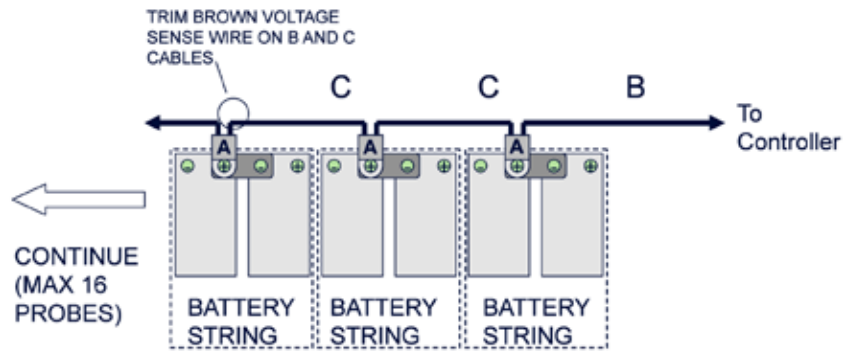

Temperature Measurement

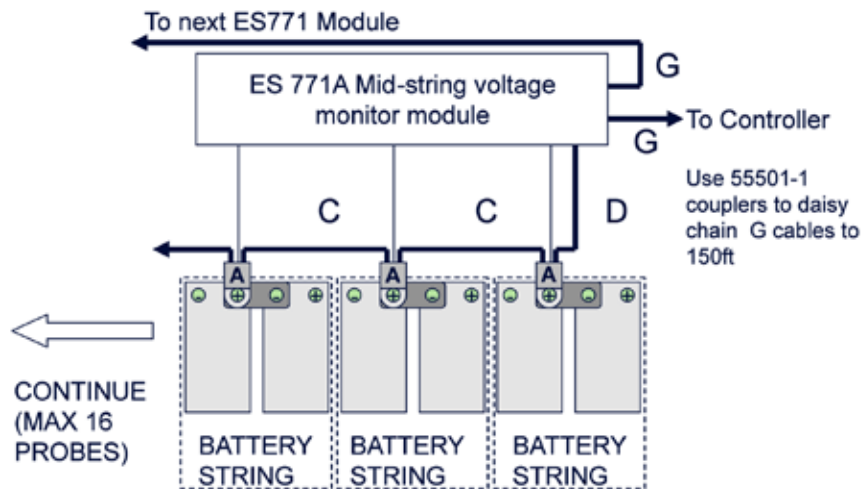

Temperature and Voltage Measurement

## Step 7: Order Additional Distribution Options (If Required)

**Extended lead times for legacy fuses and breakers.**

J85500E2	
Fuses and Fuse Holder	
Ordering Code	Description
405673146	1-1/3 amp Fuse
405181983	2 amp Fuse
406159061	5 amp Fuse
406980797	Fuse Holder, 15900-AT
407006329	Fuse, TPA-5
407006337	Fuse, TPA-10
407006345	Fuse, TPA-15
407006352	Fuse, TPA-20
407006378	Fuse, TPA-30
Circuit Breakers used with Lists 3 and 4 Distribution Modules	
Ordering Code	Description
406746313	3 amp plug-in circuit breaker kit for use with L- 4 distribution module
406746321	5 amp plug-in circuit breaker kit for use with L- 4 distribution module
406746347	15 amp plug-in circuit breaker kit for use with L- 4 distribution module
406746370	45 amp Circuit Breaker Kit for use with L- 4 distribution module
406746388	60 amp Circuit Breaker Kit for use with L- 4 distribution module
846814457	100 amp Circuit Breaker Kit for use with L- 3 distribution module
846814465	225 amp Circuit Breaker Kit for use with L- 3 distribution module
Circuit Breakers for use with Distribution Modules Lists 8, 10 and 11	
Ordering Code	Description
407098417	3 amp single-position circuit breaker
407098425	5 amp single position circuit breaker
407098433	10 amp single position circuit breaker
407098458	15 amp single position circuit breaker
407098474	20 amp single position circuit breaker
407098482	25 amp single position circuit breaker
407098490	30 amp single position circuit breaker
407245448	40 amp single position circuit breaker
407098508	45 amp two position circuit breaker
407098516	45 amp single position circuit breaker
407098524	50 amp single position circuit breaker
407098532	60 amp two position circuit breaker
407098540	70 amp two position circuit breaker
407098565	90 amp two position circuit breaker
407098573	100 amp two position circuit breaker

## Step 7: Order Additional Distribution Options (cont.)

### Extended lead times for legacy fuses and breakers.

J85500G2	
Circuit Breaker Kits for ED83119-30 Distribution Panel	
Ordering Code	Description
848241113	One 5A circuit breaker kit. Provides KS22010 circuit breaker with charge terminal, bus bar, patch cords and associated mounting hardware for use with ED83119-30 G-1 or 2 front access circuit breaker panel. (Same as ED83119-30 G-AA and J85500G2 L-AA)
848241154	One 30A circuit breaker kit. Provides KS22010 circuit breaker with charge terminal, bus bar, patch cords and associated mounting hardware for use with ED83119-30 G-1 or 2 front access circuit breaker panel. (Same as ED83119-30 G-AD and J85500G2 L-AD)
848241162	One 45A circuit breaker kit. Provides KS22010 circuit breaker with charge terminal, bus bar, patch cords and associated mounting hardware for use with ED83119-30 G-1 or 2 front access circuit breaker panel. (Same as ED83119-30 G-AE and J85500G2 L-AE)
848241188	One 60A circuit breaker kit. Provides KS22010 circuit breaker with charge terminal, bus bar, patch cords and associated mounting hardware for use with ED83119-30 G-1 or 2 front access circuit breaker panel. (Same as ED83119-30 G-AF and J85500G2 L-AF)
848241196	One 80A circuit breaker kit. Provides KS22010 circuit breaker with charge terminal, bus bar, patch cords and associated mounting hardware for use with ED83119-30 G-1 or 2 front access circuit breaker panel. (Same as ED83119-30 G-AG and J85500G2 L-AG)
848241212	One 100A circuit breaker kit. Provides KS22010 circuit breaker with charge terminal, bus bar, patch cords and associated mounting hardware for use with ED83119-30, G-1 or 2 front access circuit breaker panel. Always provided with charge terminal. (Same as ED83119-30 G-AH and J85500G2 L-AH)
848241055	One 225A circuit breaker kit. Provides single pole circuit breaker with charge terminal and shunt, bus bar, patch cords and associated mounting hardware for use with ED83119-30, G-1 or 2. (Same as ED83119-30 G-AR and J85500G2 L-AR)

ED83182-30	
Distribution Panel for Various Lineage 2000 Power Plants	
Ordering Code	Description
848238754	ED8218230GZ One 100A circuit breaker kit. Provides KS22010 front access circuit breaker w/charge terminal and associated connecting equipment
848299533	ED8318230GAB One 10A circuit breaker kit. Provides KS22010 front access circuit breaker w/charge terminal and associated connecting equipment
848299541	ED8318230GAD One 20A circuit breaker kit. Provides KS22010 front access circuit breaker and associated connecting equipment
848299525	ED8318230GAF One 30A circuit breaker kit. Provides KS22010 front access circuit breaker and associated connecting equipment
848299582	ED8318230GBL One 225A circuit breaker kit. Provides KS22012 circuit breaker w/charge switch & shunt, and associated connecting equipment

## Management Visibility

Galaxy Manager™ software is the centralized visibility and control component of a comprehensive power management system designed to meet engineering, operations and maintenance needs. The Galaxy Manager client-server architecture enables remote access to system controllers across the power network.

- Dashboard display with one-click access to management information database
- Trend analysis
- Scheduled or on demand reports
- Fault, configuration, asset, and performance management

## Training

GE Energy offers on-site and classroom training options based on certification curriculum. Technical training can be tailored to individual customer needs. Training enables customers and partners to more effectively manage and support the power infrastructure. We have built our training program on practical learning objectives that are relevant to specific technologies or infrastructure design objectives.

## Service & Support

GE Energy field service and support personnel are trusted advisors to our customers – always available to answer questions and help with any project, large or small. Our certified professional services team consists of experts in every aspect of power conversion with the resources and experience to handle large turnkey projects along with custom approaches to complex challenges. Proven systems engineering and installation best practices are designed to safely deliver results that exceed our customers' expectations.

## Warranty

GE Energy is committed to providing quality products and solutions. We have developed a comprehensive warranty that protects you and provides a simple way to get your products repaired or replaced as soon as possible.

For full warranty terms and conditions please go to [www.ge.com/powerelectronics](http://www.ge.com/powerelectronics).



GE Energy

## Contact Us

For more information, call us toll free at **+1 877 546 3243**, or +1 972 244 9288 and visit us on the web at [www.ge.com/powerelectronics](http://www.ge.com/powerelectronics)